

# DB/43

MARKETING BOOK 2022



## S U M M A R Y

---

SPECIFICATIONS

CONCEPT

EXTERIOR

INTERIOR

ATMOSPHERE

ELECTRONIC PACK

TECHNICAL INFORMATION

---



\*.You can return to this page at anytime. Click on the Jeanneau logo, at the top of the page.

<b>Overall length (OB with engines up)</b>	IB : 13,03 m / 42'9" – OB : 13,94 m / 45'8"
<b>Hull length</b>	11,15 m / 36'6" - OB : 11,95 m / 39'2"
<b>Beam</b>	3,82 m / 12'6"
<b>Beam with open terraces</b>	5,67 m / 18'7"
<b>Draft</b>	0,94 m / 3'1"
<b>Cabins</b>	2
<b>Berths</b>	4 or 5
<b>Heads</b>	1 or 2
<b>Inboard engines</b>	Volvo 2 x D6-380 HP Joystick
<b>Outboard engines</b>	Mercury 3 x 350 HP Verado Joystick
<b>Designer</b>	GARRONI Design
<b>Architect</b>	Michael PETERS
<b>CE certification</b>	B 10 / C 12



CONCEPT

# DB/43

  
JEANNEAU







## Philosophy of the DB range :

- **PREMIUM DAYBOAT**
- **HARMONIOUS - PURE - SOPHISTICATED – POWERFUL**
- **AN HABITABLE & TIMELESS DAYBOAT**

*“ With the DB/43, Jeanneau integrates **the expected codes** in the segment of **premium Day Boats**, in terms of design and finish, while enriching it with an optimal interior layout, a true characteristic of Jeanneau boats. **We reinterpret this segment** by endowing the DB/43 with not only an **impactful design**, but also a **volume of living space on board** and **ingenious functionalities**, as a real invitation to extend your cruise **beyond day boating**. This step is, by the way, not new for Jeanneau, because it revives our DB line from the 1980s, and it is delivering these requirements for style and comfort. The DB/43 is thus a superb evocation of this savoir-faire.”*

Merry de la Poëze, Powerboat Product Marketing Director

- **Two electric side terraces**
- **Large outdoor galley**
- **Aft platform**
- **Very convivial and flexible cockpit**
- **Forward cockpit / Sunbathing area**

## DECK LAYOUT

- 1 Modular front cockpit
- 2 Aft platform  
(option: hydraulic version)
- 3 Large front sundeck
- 4 Side boarding gate
- 5 Electric opening Sportop





## COCKPIT LAYOUT

- 1 Wide passage (51cm)
- 2 Exterior galley
- 3 Side terraces
- 4 Modular cockpit
- 5 Sunbed



## Big aft swim platform

(option : hydraulic)

Maximum loading capacity while cruising : 150 kg / 330 lbs

- 1 Shore power
- 2 Integrated bathing ladder
- 3 Mooring cleats

12'6"  4'7" 

3,80m  1,40m 



## MODULAR COCKPIT

- 1 Backrest in sunbed position
- 2 Backrest in facing position
- 3 Backrest in navigation / facing position
- 4 Table in dinner position

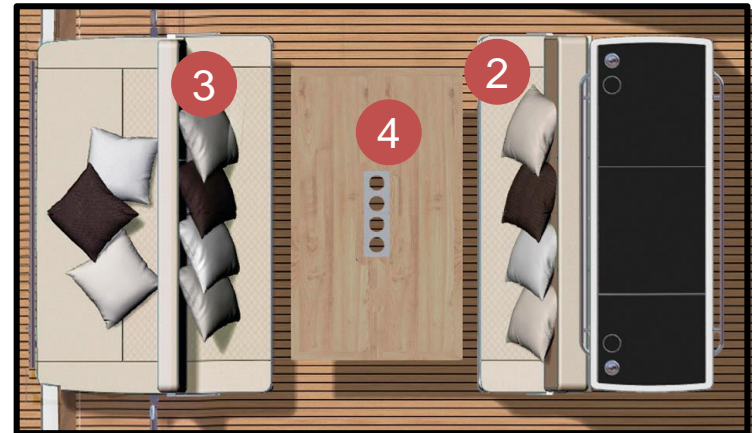
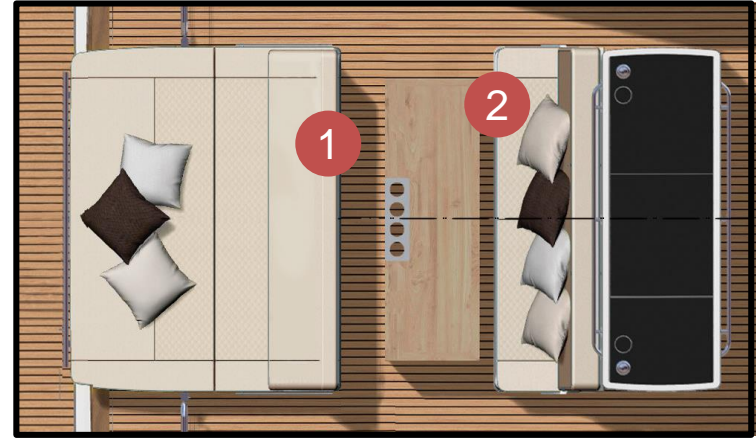

## MODULAR COCKPIT

1 2 benches in navigation direction

Possibility of seating 4 people per bench.

With the 3 pilot seats : a total of 11 people are seated in navigation direction.

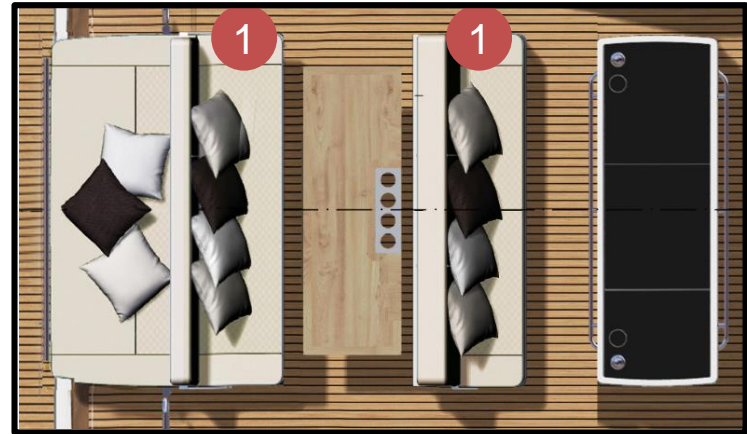



## MODULAR COCKPIT

Large folding cockpit table with 3 different positions

Table size :

5'7"  3'3" 

170 cm  100 cm 



EXTERIOR

DB/43



MODULAR AFT SUNBED





## EXTERIOR STORAGE

Under the aft sunbed

- 1 Storage under the sunbed cushion
- 2 BIB access
- 3 Large, electrically opening trunk, with control switch at the dock outlet
- 4



Capacity : 970 L / 256 US Gal



## BIB HOLDER

Under the aft sunbed

- 1 BIB holder with clip

Place for 2 BIB, 6 persons





## TECHNICAL INFORMATION

1 Access to dock outlet on portside



2 Outside shower, 4 fresh and 5 sea water deck wash downs (optional)



3 Bilge pump (portside)

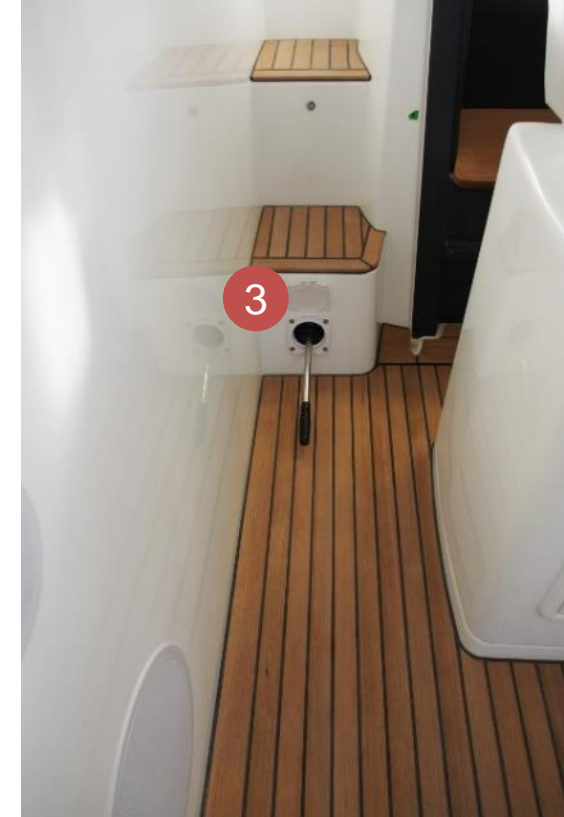

OB VERSION - AUTO FLUSH SWITCH



DIESEL TANK FOR GENERATOR



## COCKPIT

### Sliding front bench

2 main positions

2 Front bench in dinner position



3 Front bench in navigation position





## ACCESS TO ENGINE ROOM

Access through a hatch when the front bench is leaning on the kitchen (position 1)

65 cm  85 cm 

Engine access

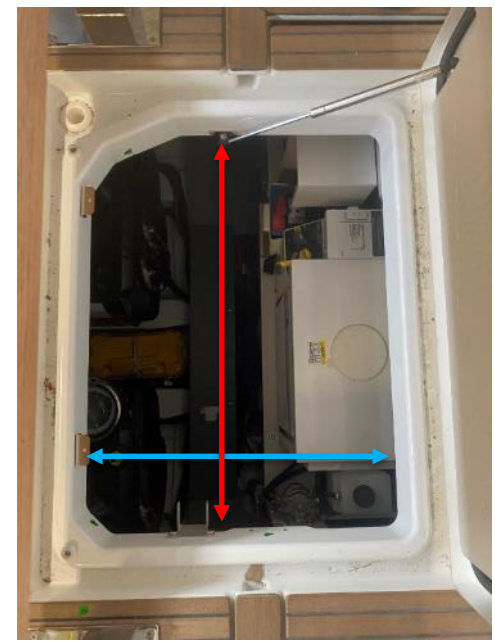
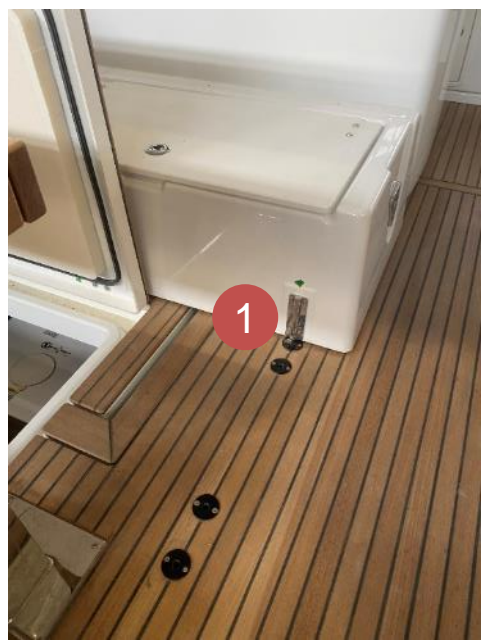

 2'2"  2'9"

## FUEL FILLER ACCESS

Access to the fuel filler when the front bench is in the furthest back position.

(position 4)

When refueling: Remember to wet the deck to avoid staining the teak.

Fuel filler access

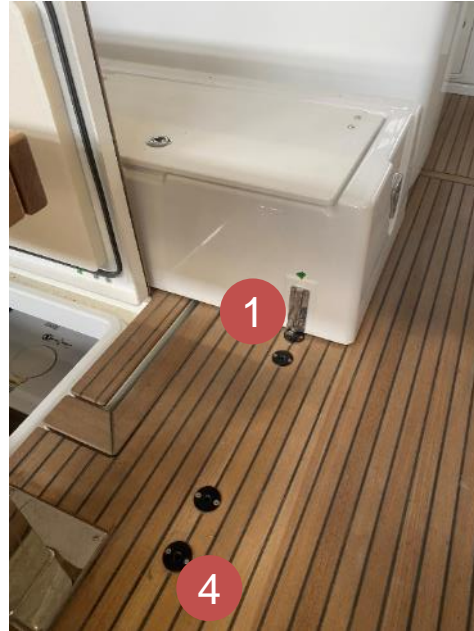

## EXTERIOR STORAGE

- 1 Large storage under the front bench



  
 81 cm    37,5 cm    1'3"    2'8"

Depth : 28 cm / 0'11"

- 2 Storage under the pilot's seat  
(replaced by cockpit air conditioning in option)

  
 67 cm    41 cm    2'2"    1'4"

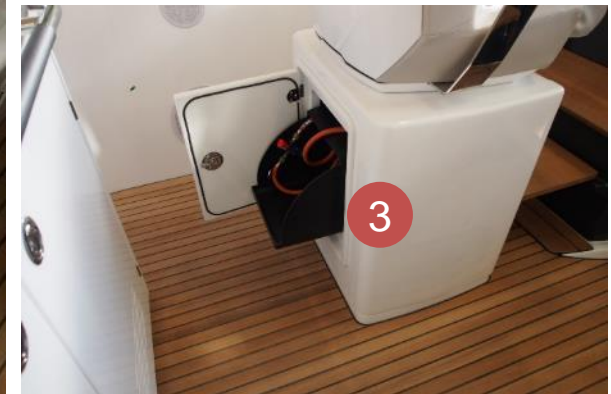
- 3 Gas box under the 3rd co-pilot seat





## COCKPIT

TV pre-rigging option in the aft cockpit



1

Control switch for the television located under the sink in the exterior galley

Remember to open the trap door before lifting down the television.





## EXTERIOR GALLEY



Retractable ambient lights  
(COMFORT PACK)



## EXTERIOR GALLEY

- 1 Sink
- 2 Bin
- 3 Fridge 65 L

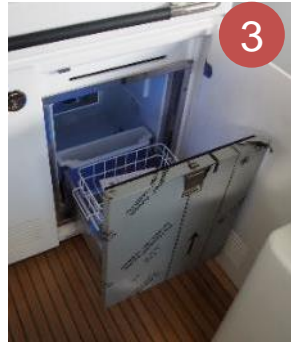



## EXTERIOR GALLEY

1

Standard : Gas stove + gas plancha  
Option :  
Vitroceramic hob and electric grill  
or  
2 electric grills

2

Standard : Storage  
Option : Second fridge 65L  
(photo)  
or  
Icemaker

3

3 drawers



## EXTERIOR GALLEY



Manual bilge pump lever



Passage for cables when using the sockets with the door closed



220V and USB plugs under the sink

## EXTERIOR GALLEY



Storage of sink lids under the drawers



EXTERIOR

# DB/43



## HELM STATION



Jeanneau DB 43 - Mention obligatoire / Mandatory credit: Photo Nicolas Clais



Jeanneau DB 43 - Mention obligatoire / Mandatory credit: Photo Nicolas Clais



Jeanneau DB 43 - Mention obligatoire / Mandatory credit: Photo Nicolas Clais

## OPENING SPORTOP

- 1 Control switch





## HELM STATION

- 1 2 cup holders
- 2 Optional air conditioning (requires the interior air conditioning)
- 3 Raymarine VHF
- 4 Secured storage box with USB plugs

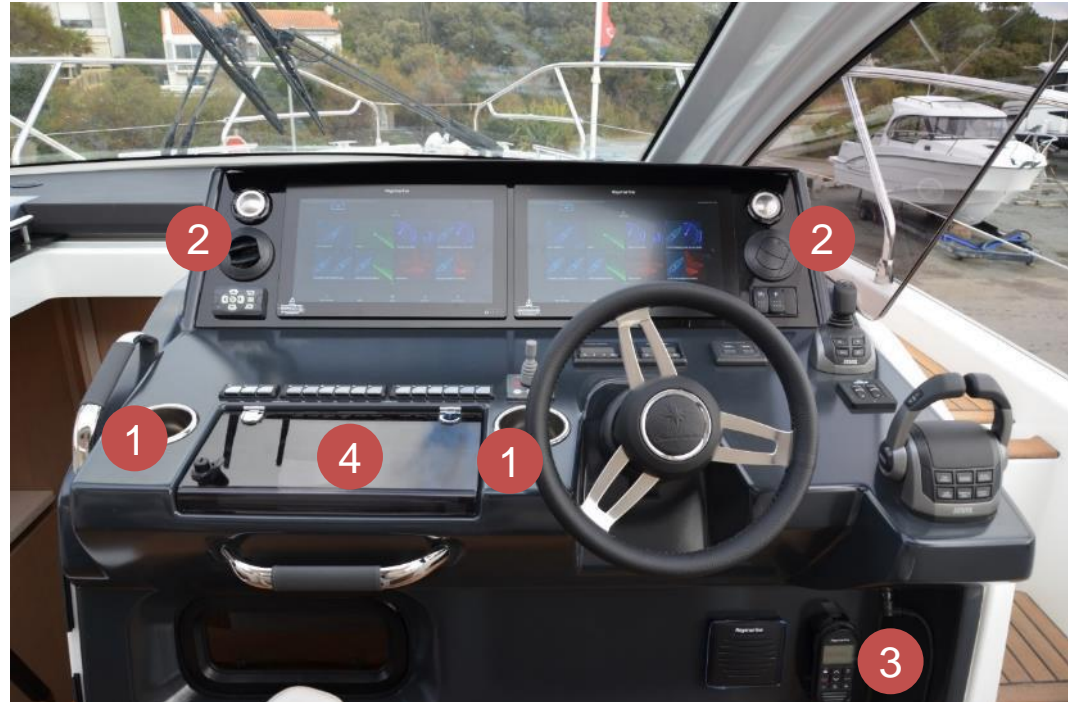

## OPENING OF THE SIDE TERRACES

Max loading : 120 kg

- 1 Activation of the control switch
- 2 Safety lock (in cruising !)
- 3 Control switch for opening and closing



**Warning**, think to deactivate the opening and closing when the terraces are open. Refer to owners manual.

## MULTI-FUNCTIONS WHEEL



## HELM STATION



Emergency levers, in the  
starboard closet of the VIP  
cabin





## PREMIUM AUDIO SYSTEM

in option

FUSION READER WB670 with amplifier

- 1 6 loudspeakers (2 front cockpit, 4 aft cockpit)
- 2 2 Subwoofers (COCKPIT portside & starboard)
- 3 2 Tweeters at the helm station

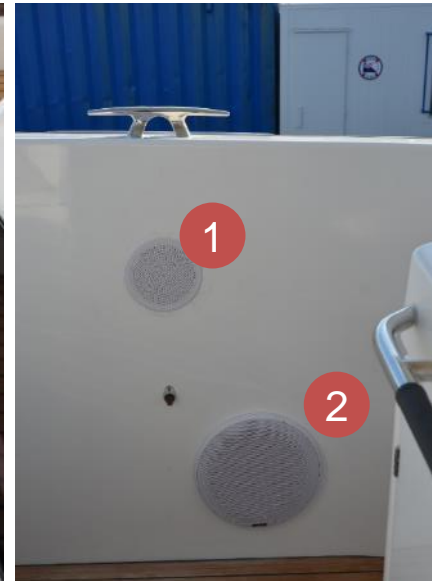
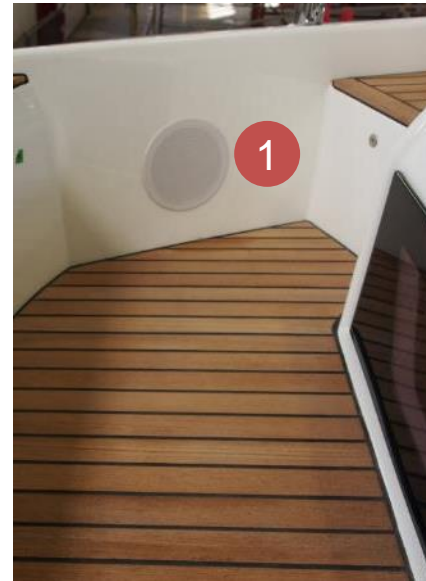

Audio system in Trim Level Premiere

Stereo Fusion reader BB100

4 loudspeakers in the aft cockpit



## HELM STATION



3 bolster seats on slides + folding footrests



2 co-pilot cup holders + storage

## SUNBED / FRONT COCKPIT

- 1 Large storage with hanging rail for fenders
- 2 Front sunbed with lifting backrets to get a face to face cockpit
- 3 Front cockpit table (option)
- 4 Retractable ambient lights (COMFORT PACK)

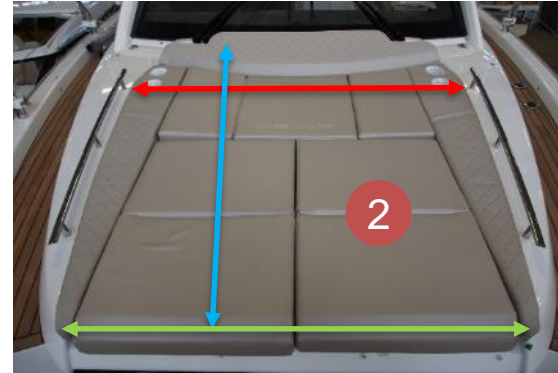

170 cm 178 cm 130 cm  
 5' 7" 5' 10" 4' 3"



## ANCHOR LOCKER

- 1 Seawater inlet for anchor locker washing (option)
- 2 Windlass with control at the helm station
- 3 Stainless steel anchor in the anchoring kit
- 4 Fenders storage next to the anchor storage
- 5 2 retractable ambient lights (COMFORT PACK)





## 4 MULTICOLOR UNDERWATER LIGHTS (option)



## EXTERIOR SAFETY

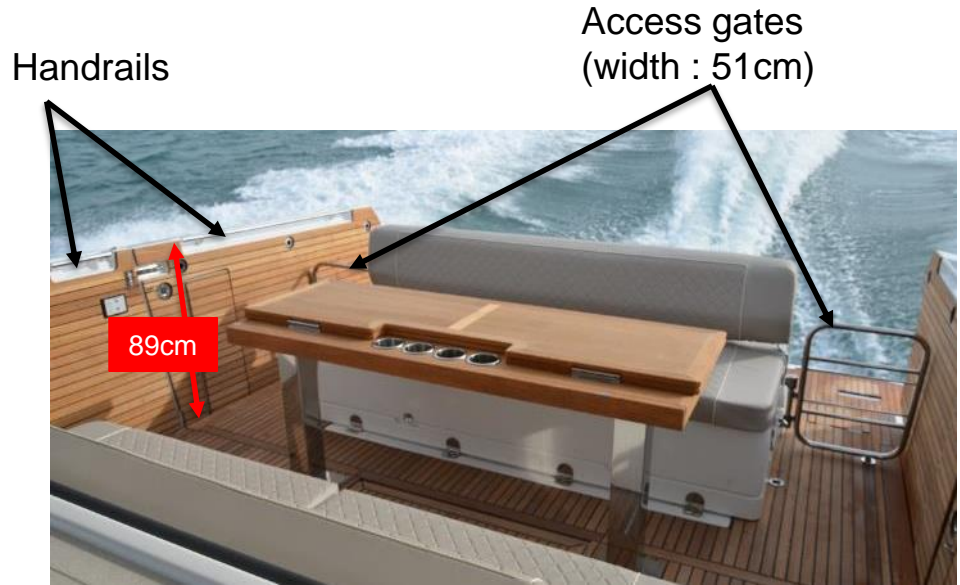

Secured swim platform



Handrail at the helm station



Safe access from the aft to the helm station thanks to the handrails

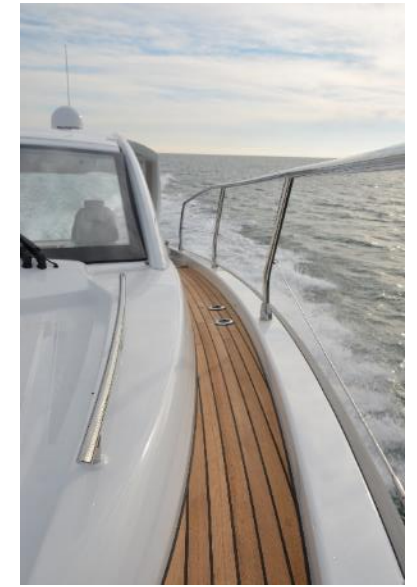

Safe sidedeck with pulpit and handrail



EXTERIOR

# DB/43



## SURESHADE

OPTION

Electrically sliding



## COCKPIT SUN AWNING

option





## COCKPIT ENCLOSURE OPTION



**1** Closing canvas for sidedecks portside and starboard

**2** Cockpit closing canvas

**3** Cockpit sun awning included

## COCKPIT GALLEY ENCLOSURE OPTION

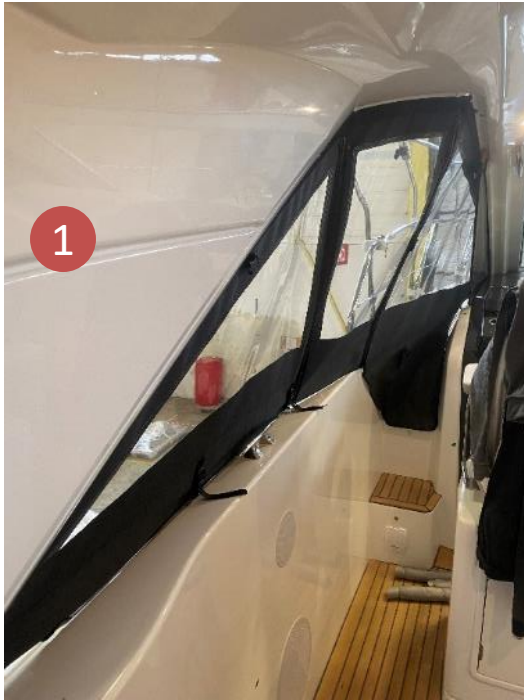

1 Closing canvas for sidedecks portside and starboard

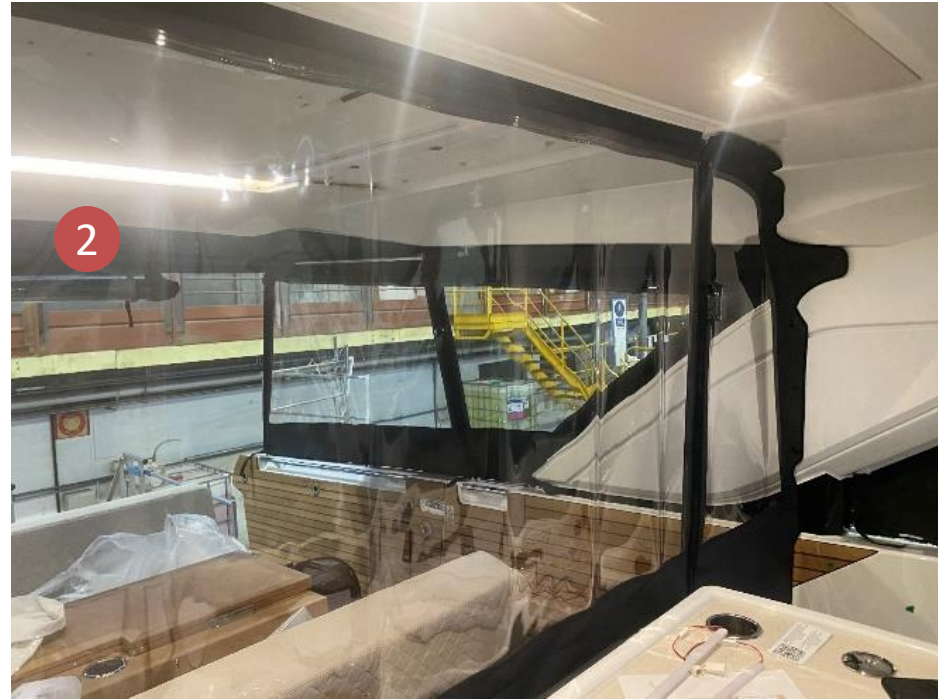

2 Closing canvas between the galley and the cockpit



## SUNSHADE OPTION

Sunshade for front cockpit  
on carbon poles



## PROTECTION COVERS

1 Sunbed, cockpit and cockpit table (covers included)



2 The Trim Level Premiere includes the following covers : aft cockpit table, helm station, 3 bolster seats, galley , aft bench and sunbed

3



- 2 cabins
- 1 Head + 1 Breakfast Point or 2 Heads

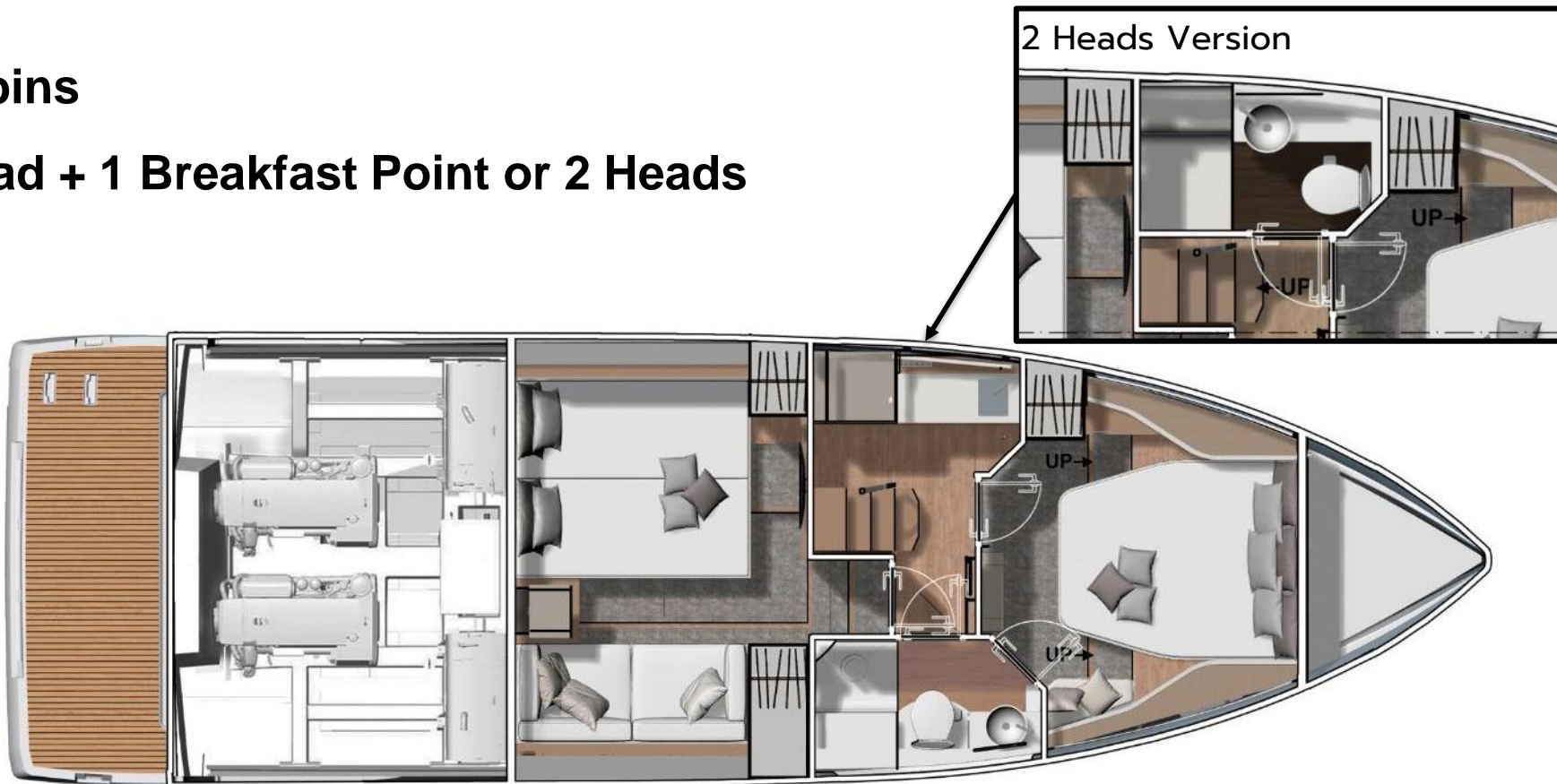

## MASTER CABIN



Jeanneau DB 43 - Mention obligatoire / Mandatory credit: Photo Nicolas Claris



Jeanneau DB 43 - Mention obligatoire / Mandatory credit: Photo Nicolas Claris



## MASTER CABIN



Jeanneau DB 43 - Mention obligatoire / Mandatory credit: Photo Nicolas Claris



Jeanneau DB 43 - Mention obligatoire / Mandatory credit: Photo Nicolas Claris

## MASTER CABIN



Jeanneau DB 43 - Mention obligatoire / Mandatory credit: Photo Nicolas Claris



Jeanneau DB 43 - Mention obligatoire / Mandatory credit: Photo Nicolas Claris

## STORAGE IN THE MASTER CABIN

- 1 Lacquered storage portside
- 2 Lacquered storage starboard
- 3 Air conditioning



## STORAGE IN THE MASTER CABIN

- 1 Wardrobe with stand-up mirror
- 2 Storage drawer under the bed
- 3 Vanity / Bar furniture (comfort pack)





## MATTRESS DIMENSIONS MASTER CABIN

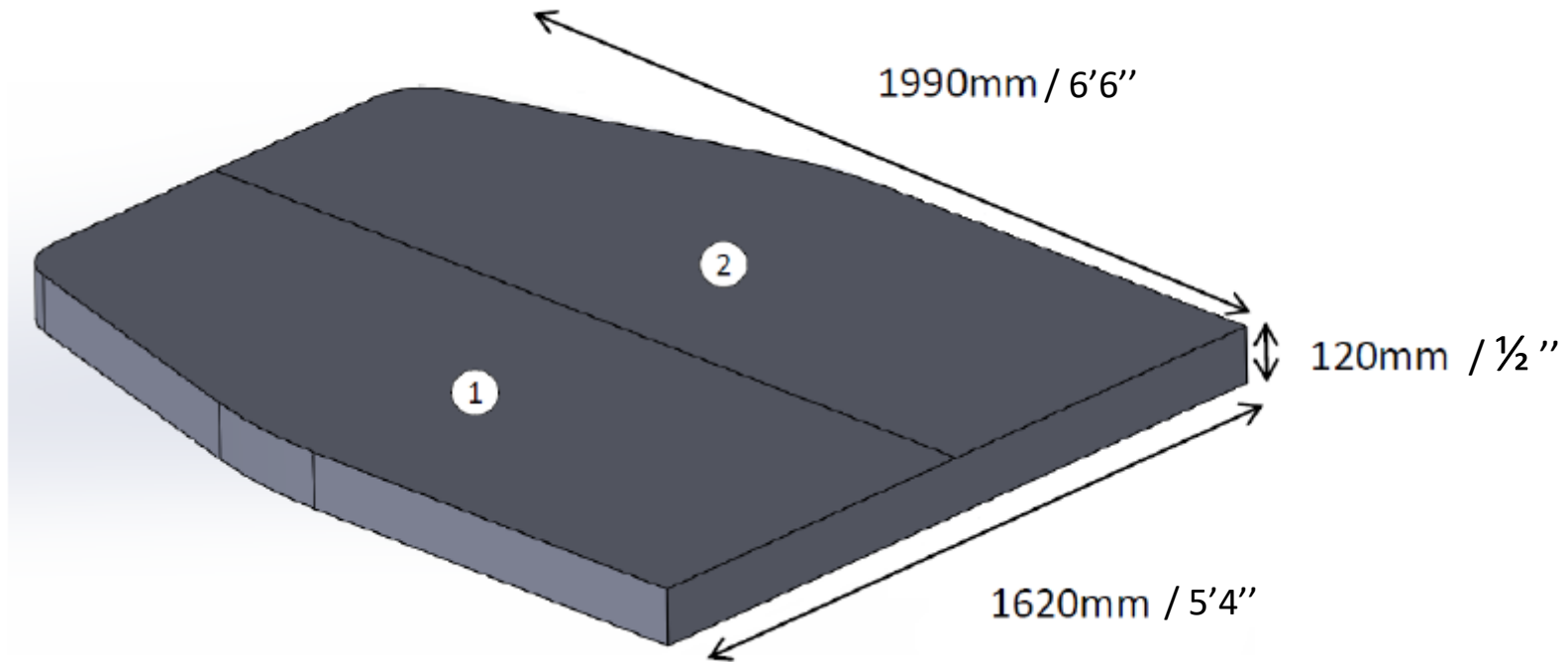

## VIP CABIN

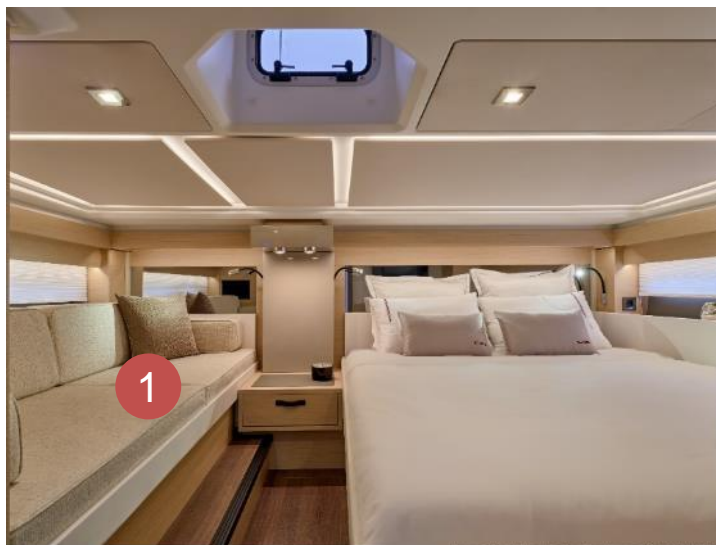

Jeanneau DB 43 - Mention obligatoire / Mandatory credit: Photo Nicolas Carls

- 1** Standard / Bed  
Option : Sofa (photo)



Jeanneau DB 43 - Mention obligatoire / Mandatory credit: Photo Nicolas Carls

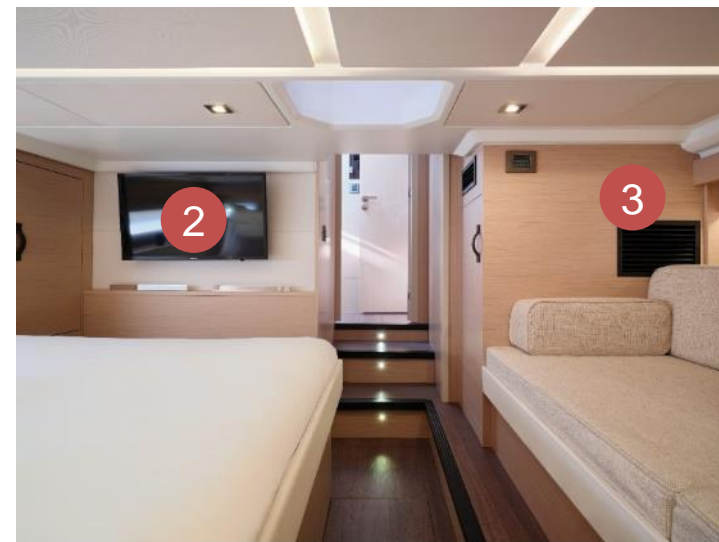

Jeanneau DB 43 - Mention obligatoire / Mandatory credit: Photo Nicolas Carls

- 2** TV pre-rigging (option)
- 3** Interior air conditioning (option)

## STORAGE IN THE VIP CABIN

- 1 Air conditioning
- 2 Wardrobe starboard
- 3 Storage drawer in bedside table
- 4 Wardrobe portside



## STORAGE IN THE VIP CABIN

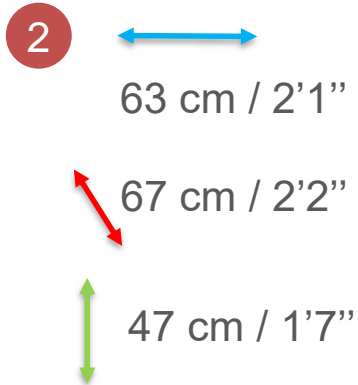
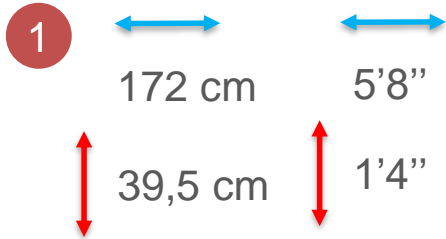

Storage under the bed, all the bed long



## MATTRESSES DIMENSIONS VIP CABIN

Mattress single bed starboard

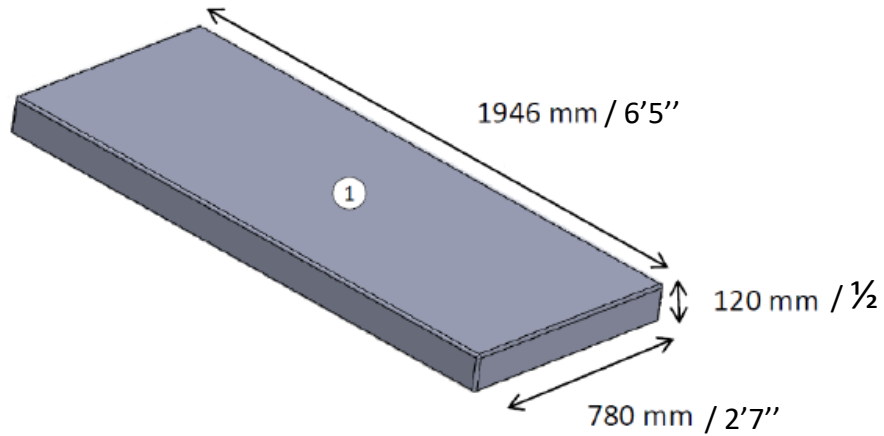

Mattress double bed portside

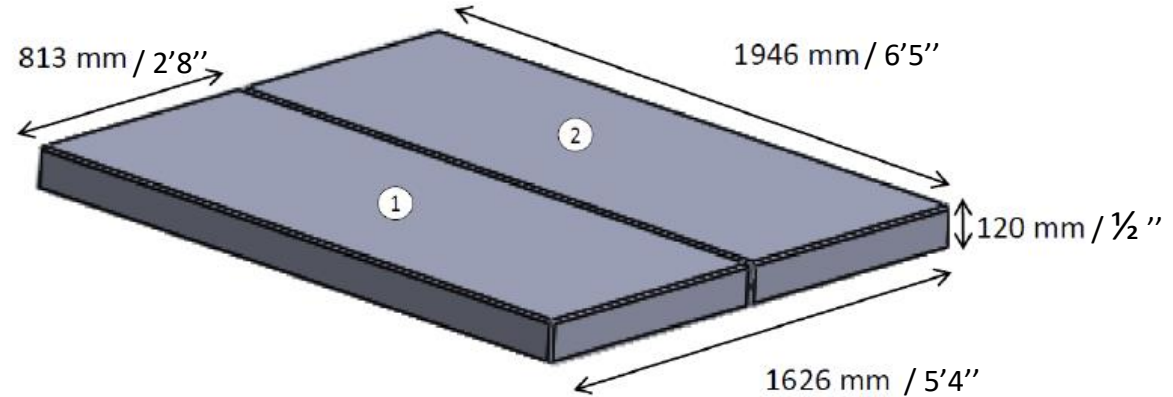

**HEAD**  
starboard



Jeanneau DB 43 - Mention obligatoire / Mandatory credit: Photo Nicolas Claret



Jeanneau DB 43 - Mention obligatoire / Mandatory credit: Photo Nicolas Claret



Jeanneau DB 43 - Mention obligatoire / Mandatory credit: Photo Nicolas Claret

## BREAKFAST POINT



Jeanneau DB 43 - Mention obligatoire / Mandatory credit: Photo Nicolas Claris



Jeanneau DB 43 - Mention obligatoire / Mandatory credit: Photo Nicolas Claris



Jeanneau DB 43 - Mention obligatoire / Mandatory credit: Photo Nicolas Claris



## STORAGE IN THE BREAKFAST POINT



Jeanneau DB 43 - Mention obligatoire / Mandatory credit Photo Nicolas Clais



Integrated drawers under the steps



Storage racks under the galley floor



## BREAKFAST POINT

- 1 Coffee machine integrated in the furniture (COMFORT PACK)
- 2 Bottles racks
- 3 Bin



## VENTILATION !



## EXTERIOR

**SELLERIE /**  
*UPHOLSTERY*



**MACADAMIA /**  
**SILVERTEX**  
**WHITE**

**SELLERIE /**  
*UPHOLSTERY*



**ICE /**  
**SILVERTEX**  
**BLUE**

**CAPOTAGES /**  
*AWNINGS*



**SUNBRELLA**  
**GRAPHITE**

## EXTERIOR

ICE /  
SILVERTEX  
BLUE





## INTÉRIEUR / INTERIOR

### Boiserie intérieure standard /

*Interior woodworks standard*



**CHÊNE FLOTTÉ /  
WHITE OAK**



**PLANCHER CHÊNE  
BRUN / BROWN OAK  
FLOOR**

### Tissu et cuir intérieur / Fabric and leather interior



**STANDARD  
IVORY**

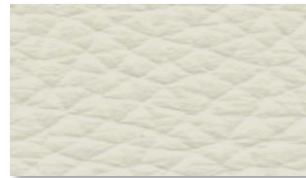

**CUIR BLANC CASSÉ /  
OFF-WHITE LEATHER**



**CUIR MARRON /  
BROWN LEATHER**

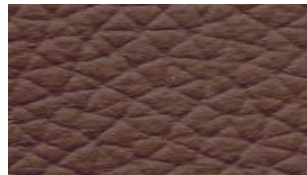

**CUIR COGNAC /  
COGNAC LEATHER**



**CUIR BEIGE /  
BEIGE LEATHER**



**CUIR TAUPE / TAUPE  
LEATHER**

### Literie / Bedding



**Literie Premium /  
Premium bedding**

ATMOSPHERE

# DB/43



Jeanneau DB 43 - Mention obligatoire / Mandatory credit: Photo Nicolas Carré



Jeanneau DB 43 - Mention obligatoire / Mandatory credit: Photo Nicolas Carré



natural home linen

## MASTER CABIN

## Cabine Avant / Forward Cabin

Linge de lit en satin de coton 300 TC

- 1 Drap-housse sur-mesure gris
- 1 Housse de couette blanche 220 x 230 cm
- 2 taies d'oreillers 50 x 70 cm – blanc + bourdons et signature DB brodée
- 2 taies d'oreillers 65 x 65 cm – blanc + bourdon gris perle tout le tour
- 1 Coussin décoratif 30 x 50 cm – avec signature DB brodée
- 1 Couvre lit sur-mesure
- 1 Couette 220 x 230 cm – garnissage coton
- 2 Oreillers 50 x 70 cm – garnissage laine de mérinos
- 2 Oreillers 65 x 65 cm – garnissage laine de mérinos

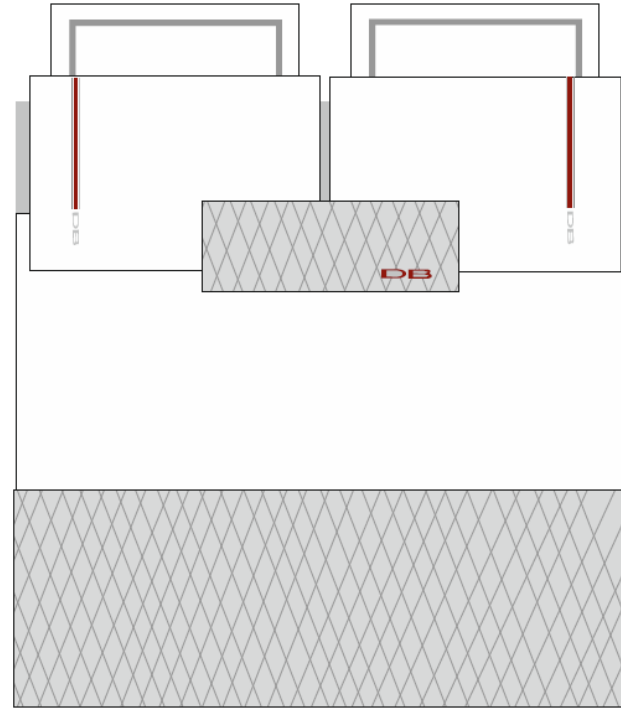

natural home linen

## VIP CABIN

## Cabine Arrière / Aft Cabin

Linge de lit en satin de coton 300 TC

- 2 Draps housses sur-mesure gris
- 1 Housse de couette blanche 220 x 230 cm
- 1 Housse de couette blanche 120 x 230 cm
- 2 taies d'oreillers 50 x 70 cm – blanc + bourdons et signature DB brodée
- 1 taies d'oreillers 50 x 70 cm – blanc + bourdons de chaque côté de la taie
- 3 taies d'oreillers 65 x 65 cm – blanc + bourdon gris perle tout le tour
- 1 Coussin décoratif 30 x 50 cm – avec signature DB brodée
- 1 Coussin décoratif 40 x 40 cm – avec signature DB brodée
- 2 Couvres lits sur-mesure
- 1 Couette 220 x 230 cm – garnissage coton
- 1 Couette 120 x 230 cm – garnissage coton
- 3 Oreillers 50 x 70 cm – garnissage laine de mérinos
- 3 Oreillers 65 x 65 cm – garnissage laine de mérinos

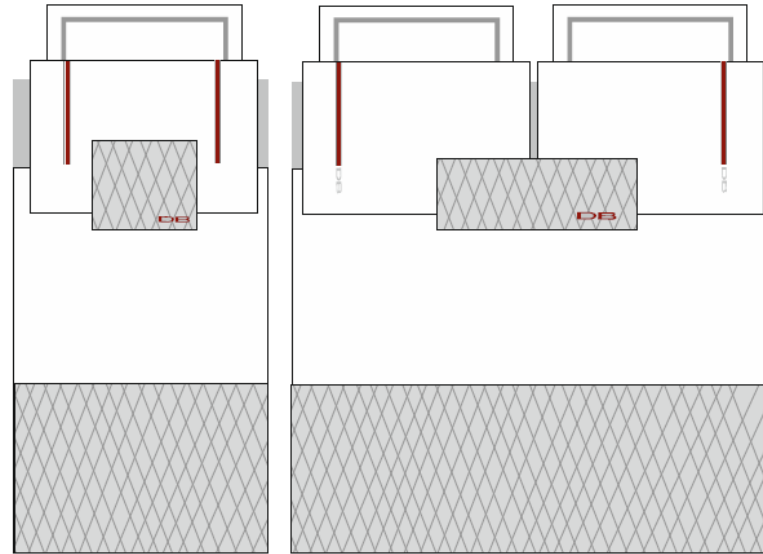

natural home linen



## ELECTRONIC PACK

# Raymarine



### Axiom XL16 Multifunction Touchscreen 16" Display



CP370 Digital Network Sonar Module  
Raymarine part number : **E70297**

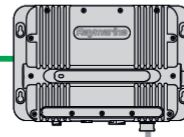

Touchscreen Multifunction display,  
Charts EU, US or ROW supplied.  
View and take control of Axiom Series from your tablet or  
smartphone using built-in Wi-Fi and Raymarine mobile apps.  
Can be connected to the Fusion Link equipment.  
Raymarine part number : **E70399**



Inhull Depth Transducer.  
Raymarine part number : **E66008**

## UPGRADED ELECTRONIC PACK



# Raymarine



Touchscreen Multifunction display,  
Charts EU, US or ROW supplied.  
View and take control of Axiom Series from your tablet or  
smartphone using built-in Wi-Fi and Raymarine mobile apps.  
Can be connected to the Fusion Link equipment.  
Raymarine part number : **E70399**

In Hull Depth Transducer.  
Raymarine part number : **E66008**



## ELECTRONIC OPTIONS

### RAY90 DSC VHF radio



Supplied with handset and loudspeaker  
Raymarine part numbers : **E70492 all versions**

### Evolution Autopilot



Autopilot control on the Multifunction display.  
Electronics compass with built-in Rate Gyro EV-2  
and CAN control. Raymarine part number : **E70097**

### Autopilot control unit - Autopilot option needed



Autopilot control head p70Rs  
Raymarine part number : **E70332**

### ClearCruise Augmented Reality function for Axiom

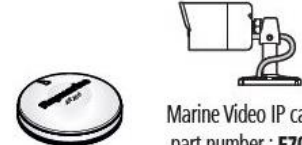

AR200 IP Camera stabilisation  
part number : **E70537**

Marine Video IP camera  
part number : **E70346**

### Class B AIS transceiver

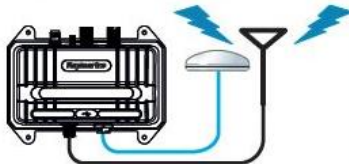

AIS700 class B AIS transceiver with built-in  
antenna splitter.  
Receive and transmit AIS navigation status  
information on Axiom.  
Raymarine part number : **E70476**

### Quantum 2 CHIRP Radar 24 MN



Quantum 2 Doppler antenna using CHIRP Pulse  
Compression technology and Doppler collision  
avoidance technology.  
Raymarine part number : **E70498**

### Open array Magnum radar antenna 72NM











Magnum open array  
antenna Super HD 4kw 72NM.  
Raymarine pn : **E70484 + E70490 + A80230**

# SHIP CONTROL

option



<p> <b>Eclairages</b> Gestion des éclairages (ON/OFF/dimmage) par zone (timonerie, cabines, cuisine...)</p>	<p> <b>Jauges</b> - Monitoring des niveaux de réservoirs (carburant, eau, eaux noires...) - Vidange - Débitmètre - Visualisation des alarmes</p>
<p> <b>Climatisation</b> Mise en route compresseur et gestion des T° par zone</p>	<p> <b>Gestion AC</b> - Pilotage des sources AC contrôle groupe électrogène et convertisseur - Visualisation des alarmes (inversion de polarité)</p>
<p> <b>Navigation</b> - Affichage des données de navigation - Gestion compteur de chaîne</p>	<p> <b>Pompes de cale</b> - Contrôle des pompes de cale - Visualisation des alarmes</p>
<p> <b>Hifi</b> - Contrôle hifi (timonerie, flybridge, cockpit) - Contrôle général (ATOLL ou Fusion)</p>	<p> <b>Moteurs</b> Affichage données moteurs</p>
<p> <b>Batteries</b> - Monitoring des tensions des parcs batteries (bord, moteurs, propulseurs...) - Monitoring courant et charge si IBS - Visualisation des alarmes</p>	<p><b>Connexion</b> Application disponible sur les écrans de navigation et sur les équipements connectés au wifi interne du bateau Version smartphone à partir de la version du serveur V8.7.1</p>



## SEAKEEPER

option

SK3 option requires :

- **Lithium batteries replacing AGM batteries for seakeeper**
- **2 x 60 Ah battery chargers**



DB43



### Volvo D6-380

#### Caractéristique / Specifications:

2 moteur In Bord / In Board engines:D6 380

Hélice / Propeller:H4

Déplacement total du bateau / Total displacement of boat tested:13821 Kg

Regime en tours par minute au tableau de bord / RPM on instrument panel	Vitesse en nœuds moyenne au radar / Average speed on the radar in knots	Consommation moteur en litres par heure / consumption engine in liter an hour	Rendement / Efficiency (L/NM = Liter per Nautical Mile)	Consommation totale en USGal / heure Total consumption in USGal/h	Rendement / Efficiency (USGal/NM)	Autonomie en miles nautiques (avec réserve 20%) /Range in Nautical Miles (with 20% fuel safety)	Remarques / Comments
600	2,7 Nds	3,0 l/h	1,11L/NM	,8 USGal/h	,29 USGal/NM	576 NM	
1000	5,9 Nds	8,2 l/h	1,39L/NM	2,2 USGal/h	,37 USGal/NM	460 NM	
1500	8,2 Nds	21,0 l/h	2,56L/NM	5,5 USGal/h	,68 USGal/NM	250 NM	
2000	10,3 Nds	50,0 l/h	4,88L/NM	13,2 USGal/h	1,29 USGal/NM	131 NM	
2500	13,4 Nds	84,0 l/h	6,27L/NM	22,2 USGal/h	1,66 USGal/NM	102 NM	
2800	18,1 Nds	106,0 l/h	5,87L/NM	28,0 USGal/h	1,55 USGal/NM	109 NM	
3000	23,4 Nds	104,0 l/h	4,44L/NM	27,5 USGal/h	1,17 USGal/NM	144 NM	
3200	26,8 Nds	124,0 l/h	4,63L/NM	32,8 USGal/h	1,22 USGal/NM	138 NM	
3400	29,7 Nds	140,0 l/h	4,72L/NM	37,0 USGal/h	1,25 USGal/NM	136 NM	
3500	30,9 Nds	142,0 l/h	4,60L/NM	37,5 USGal/h	1,21 USGal/NM	139 NM	15% trim
3600	33,1 Nds	162,0 l/h	4,90L/NM	42,8 USGal/h	1,29 USGal/NM	131 NM	33% trim

Conditions optimales théoriques et purement indicatives des essais : /Optimal theoretical conditions, purely indicative for trials :

Coque neuve, vent 5nds, mer belle petit clapot, antifouling / new hull, wind 5 knots, nice little choppy sea, antifouling

## MOORING - ANCHORING KITS

Bateaux / Boats	MOUILLAGE / ANCHORING				AMARRE / MOORING		PARE-BATTAGES / FENDERS				
	Code / Ref	Ancre / Anchor		Chaîne / Line		Code / Ref	Désignation / Détail	Code / Ref	Désignation / Détail		
DB / 43	187164	20 kg	INOX	10 mm	32 m	45 m	18 mm	119857	4 x D18 L15000 Gris / Grey	189033	6 x 700 X D.250

## PACKING LIST

Bateaux / Boats	Version	Longueur HT / Length overall (m)	Largeur HT / Width overall (m)	Hauteur Colisage / Height overall (m)	Poids est. / Est. Weight (kg)	Poids ber / Weight cradle (kg)	Longueur ber / Length cradle (m)	Largeur ber / Width cradle (m)
DB / 43	IB	13,033	3,820	4,207	14081	482	6,549	3,524
DB / 43	HB	13,935	3,820	4,207	13719	485	6,910	3,524

Poids des bateaux : moteur maxi inclus / Weight boats: with max. engine size



# DB/43

This is not a contractual document. This document was updated in  
March 2022.

It may contain illustrations or text representing or referring to optional  
equipment. If changes appear on the next model year, with regard to  
equipment or options referred to in this document, only the current  
Jeanneau rate will apply.



**JEANNEAU**